

03

Loft Project

DESIGN CONCEPT

My client is a recent empty nester in her early 50's looking to remodel her downtown loft. We will turn her space into an elegant industrial, organic retreat during this remodel. The process will include remodeling in the entryway, kitchen/dining area, living room, laundry room, guest room/office, half bath, and master suite. This will be the perfect start to a new chapter of her life with her husband. This project is to be completed by February 2020 and the budget is \$75,000.

Process Work

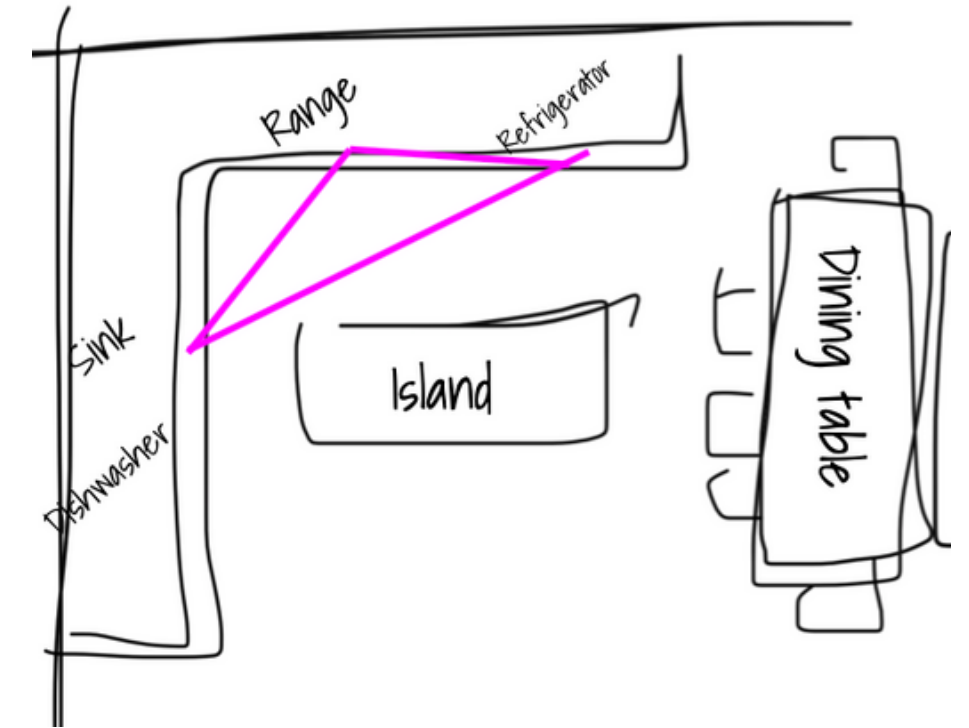

Thin-set ceramic tile detail

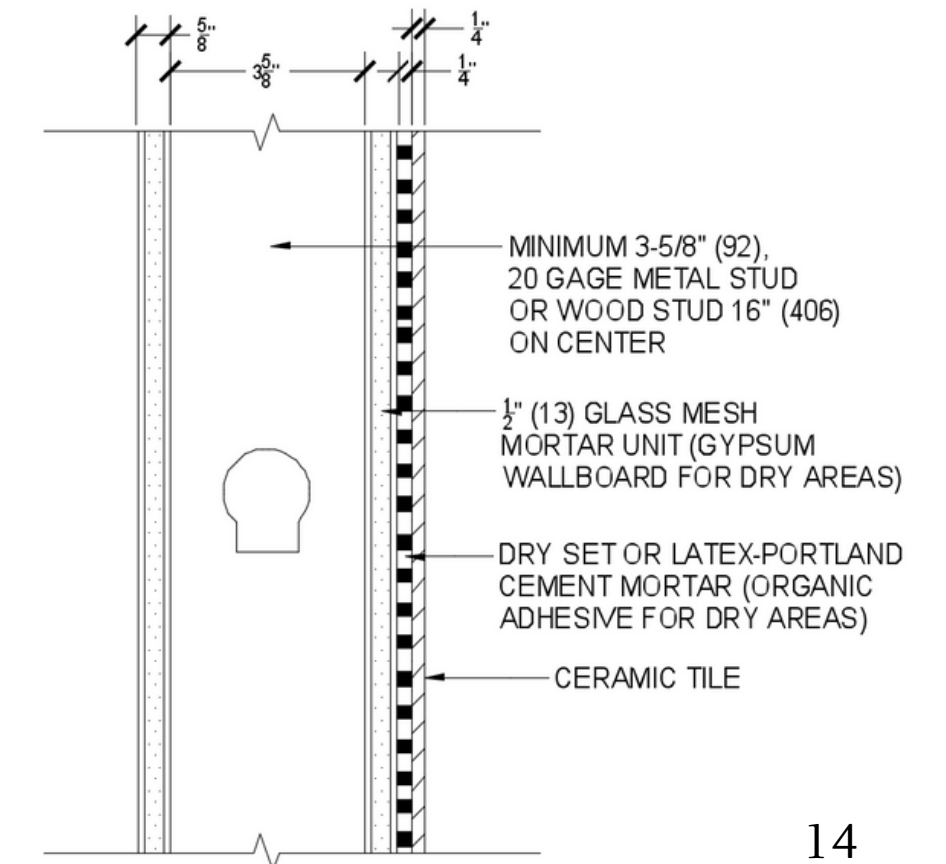

1. THIN-SET CERAMIC TILE
6"=1'-0"